

TOLERANCES

$d1$	+0.000" -0.001" (+0.000 -0.025mm)
$d2$	h6

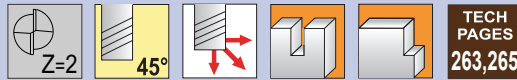

Recommended for aluminum and titanium

Square End

- Solid submicron grain carbide end mill - center cutting
- High performance machining
- Rigid work holding, machine stability and part integrity are critical!
- Excellent choice for slotting
- Polished cylindrical O.D. margin reduces chatter
- Sharp corners (Can be modified with a corner radius)

Designed for spindles between 3,000-8,000 RPM, 1% diameter for chip load

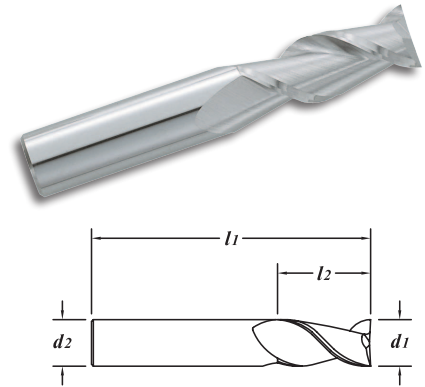

EDP#	$d1$ †		$d2$	$l1$	$l2$	1-11	12-24	25-49	50-100	
	Decimal	Diameter								Metric
08910	.1181		3.000	3.0	38	8	11.07	10.59	10.11	9.63
08920	.1181		3.000	3.0	50	12	13.34	12.76	12.18	11.60
85160	.1250	1/8"	3.175	1/8"	1-1/2"	1/4"	10.40	9.94	9.49	9.04
85170	.1250	1/8"	3.175	1/8"	2"	1/2"	12.52	11.98	11.43	10.89
08950	.1575		4.000	6.0	50	8	18.00	17.22	16.43	15.65
08960	.1575		4.000	6.0	50	12	18.00	17.22	16.43	15.65
85180	.1875	3/16"	4.763	3/16"	2"	5/16"	12.98	12.42	11.85	11.29
85190	.1875	3/16"	4.763	3/16"	2"	9/16"	12.98	12.42	11.85	11.29
08990	.1969		5.000	6.0	50	10	16.94	16.20	15.47	14.73
09000	.1969		5.000	6.0	65	15	18.84	18.02	17.20	16.38
09010	.2362		6.000	6.0	50	12	14.42	13.79	13.17	12.54
09020	.2362		6.000	6.0	65	25	15.50	14.83	14.15	13.48
09030	.2362		6.000	6.0	100	50	28.09	26.87	25.65	24.43
85200	.2500	1/4"	6.350	1/4"	2"	1/2"	13.67	13.08	12.48	11.89
85220	.2500	1/4"	6.350	1/4"	2-1/2"	1"	14.78	14.14	13.49	12.85
85240	.2500	1/4"	6.350	1/4"	4"	2"	26.69	25.53	24.37	23.21
85300	.3125	5/16"	7.938	5/16"	3"	1-1/8"	31.19	29.83	28.48	27.12
09240	.3150		8.000	8.0	65	20	21.76	20.81	19.87	18.92
09040	.3150		8.000	8.0	75	30	32.87	31.44	30.01	28.58
09050	.3150		8.000	8.0	100	50	36.66	35.07	33.47	31.88
85400	.3750	3/8"	9.525	3/8"	2"	5/8"	23.10	22.10	21.09	20.09
85420	.3750	3/8"	9.525	3/8"	2-1/2"	1"	25.81	24.68	23.56	22.44
85440	.3750	3/8"	9.525	3/8"	4"	2"	38.55	36.87	35.20	33.52
09060	.3937		10.000	10.0	50	16	26.88	25.71	24.54	23.37
09070	.3937		10.000	10.0	70	25	31.41	30.04	28.68	27.31
09080	.3937		10.000	10.0	100	50	49.13	46.99	44.86	42.72
09090	.4724		12.000	12.0	65	20	40.14	38.39	36.65	34.90
09100	.4724		12.000	12.0	75	32	43.40	41.51	39.63	37.74
09110	.4724		12.000	12.0	100	50	59.80	57.20	54.60	52.00
85500	.5000	1/2"	12.700	1/2"	2-1/2"	3/4"	37.92	36.27	34.62	32.97
85520	.5000	1/2"	12.700	1/2"	3"	1-1/4"	41.33	39.53	37.74	35.94
85540	.5000	1/2"	12.700	1/2"	4"	2"	56.42	53.97	51.51	49.06
85600	.6250	5/8"	15.875	5/8"	3-1/2"	1-5/8"	79.71	76.24	72.78	69.31
85620	.6250	5/8"	15.875	5/8"	6"	3"	116.28	111.22	106.17	101.11
09120	.6299		16.000	16.0	88	40	83.69	80.05	76.41	72.77
09130	.6299		16.000	16.0	150	75	116.28	111.22	106.17	101.11
09140	.7087		18.000	18.0	100	45	122.73	117.39	112.06	106.72
85700	.7500	3/4"	19.050	3/4"	4"	1-3/4"	116.87	111.79	106.71	101.63
85720	.7500	3/4"	19.050	3/4"	6"	3"	185.24	177.19	169.13	161.08
09350	.7874		20.000	20.0	100	38	156.03	149.25	142.46	135.68
09150	.7874		20.000	20.0	150	75	195.14	186.66	178.17	169.69
09160	.9843		25.000	25.0	100	45	181.26	173.38	165.50	157.62
09170	.9843		25.000	25.0	150	75	300.71	287.64	274.56	261.49
85800	1.000	1"	25.400	1"	4"	1-3/4"	174.82	167.22	159.62	152.02
85820	1.000	1"	25.400	1"	6"	3"	314.94	301.25	287.55	273.86

MATERIAL HARDNESS (Rc)

70

35

0

HIGH PERFORMANCE END MILLS